

Generator set
Sound-proof type
GMS200CS

SPECIFICATIONS

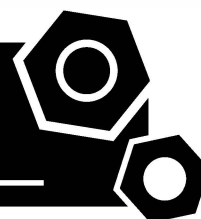

1 Standards & Conditions

Design Standards

The designs and the productions are in conformity with:

- Conformance Européenne (CE)
- China Compulsory Certification (CCC)
- ISO8528-5:2005
- GB/T2820.5-2009

Environmental Operating Conditions

- Installation place: Outdoors or indoors (well ventilated).
- Ambient temperature: -25°C to 50°C. The coolant heater is needed when the temperature is below 5°C
- Humidity: Less than 80%.
- Altitude: Below one thousand (1000) meters.

Factory Inspection

- Inspection items.
- Protection devices working test.
- Starting ability in normal temperature.
- 50% rated power load moment capability.
- Voltage deviation and speed variation: 0%, 25%, 50%, 75%, 100%, 110% Load.

Painting Process

- Painting process specifications and colors are based on the manufacturer's standard.
- The customer could also choose the color which the manufacturer offers.

2 General Features

- Cummins engine 6CTAA8.3-G2
- Close coupled to a Leroy Somer alternator LSA44.3VL14
- Microprocessor control module PLC-7420
- Main circuit breaker: 315A
- Rotate speed governor: Electrical governor S6700E
- Excitation system: Self excited
- A.V.R model: R250
- Key switch
- Emergency stop switch
- ATS (automatic transfer switch) receptacle
- 2x12V/120AH sealed for life maintenance free battery

- Lockable battery isolator switch
- Powder coated canopy
- 50°C radiator
- Oil pump on the engine
- Steel base frame with forklifts
- Vibration isolators between the engine/alternator and base frame
- Dry type air filter
- Base fuel tank for 11 hours running
- Drain points for fuel tank
- Operation Manual / Parts List / Specifications

3 Equipment Specification

General technical data



Model.....GMS200CS
 Structure type R
 Tank capacity..... 470L
 Dry weigh..... 2695kg
 Sound pressure level @7m70dB(A)
 Sound power level acc. 2000/14/EC98dB(A)
 Dimensions L×W×H.....3592×1840×1322mm
 Standby Power 220kVA/176kW
 Prime Power 200kVA/160kW

Voltage	380V	400V	415V	440V	
Ampere	303.9A	288.7A	278.2A	262.4A	
Genset Fuel Consumption					
Frequency/Load	25%	50%	75%	100%	110%
50Hz (L/h)	13	23	34	45	51

Dck Yf' GrghYa

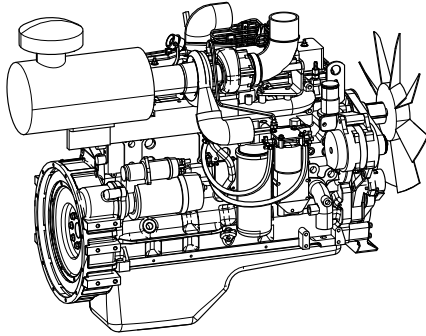

Engine Manufacturer/Brand.....	Cummins
Engine Model.....	6CTAA8.3G2
Dimensions L×W×H.....	1485.3*866.5*1245.0
Dry Weigh (approx.).....	702kg
Number of Cylinders.....	6
Bore.....	114mm
Stroke.....	135mm
Displacement.....	8.3L
Compression Ratio.....	16.7
Type of injection.....	Direct injection
Intake System.....	Turbocharged,water-to-air charge cooled
Intake Resistance.....	≤6.28kPa
Cooling System.....	Water cooled
Fan.....	Pusher
Battery Voltage.....	12/24V
Type of Fuel.....	Diesel
Type of Oil.....	ACEA E2, API CF, CF-4, CG-4
Oil Capacity.....	23.8L
Type of Coolant.....	Glycol mixture
Coolant Capacity.....	45.3L
Back Pressure.....	≤10.1kPa
Standby Power.....	203kW
Prime Power.....	183kW
Fuel Consumption(100%load).....	45L/h

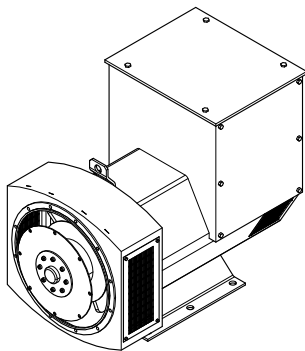

Alternator Manufacturer/Brand.....	Leroy Somer
Alternator Model.....	LSA44.3VL14
Exciter.....	Brushless
Cooling Fan.....	Cast alloy aluminum
Windings.....	100% copper
Insulation Class.....	H
Winding Pitch.....	2/3
Terminals.....	12
Drip Proof.....	IP23
Altitude.....	≤1000m
Overspeed.....	2250rpm
Air Flow.....	0.514m³/s(50Hz),0.617m³/s(60Hz)
Voltage Regulation.....	±1.0%
Total Harmonic TGH / THCat no load < 1.5 % - on load < 5%	
Telephone Interference.....	THF<2%;TIF<50

PLC-7420 Control System

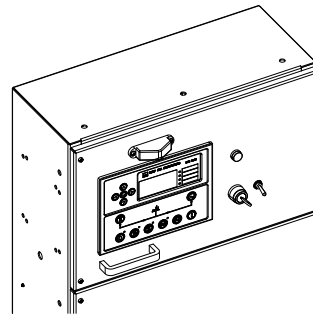

PLC-7420 is an advanced control module based on micro-processor, containing all necessary functions for protection of the genset and the breaker control. It can monitor the mains supply, and automatically start the engine when the mains is abnormal. Accurately measure various operational parameters and display all values and alarms information on the LCD. In addition, the control module can automatically shut down the engine and indicate the engine failure.

- Microprocessor control, with high stability and credibility
- Monitoring and measuring operational parameters of the mains supply and genset
- Indicating operation status, fault conditions, all parameters and alarms
- Multiple protections; multiple parameters display, like pressure, temp. etc.
- Manual, automatic and remote work mode selectable
- Real time clock for time and date display, overall runtime display, 250 log entries
- Overall power output display
- Integral speed/frequency detecting, telling status of start, rated operation, overspeed etc.
- Communication with PC via RS485 OR RS232 interface, using MODBUS protocol

4 Overall Dimensions

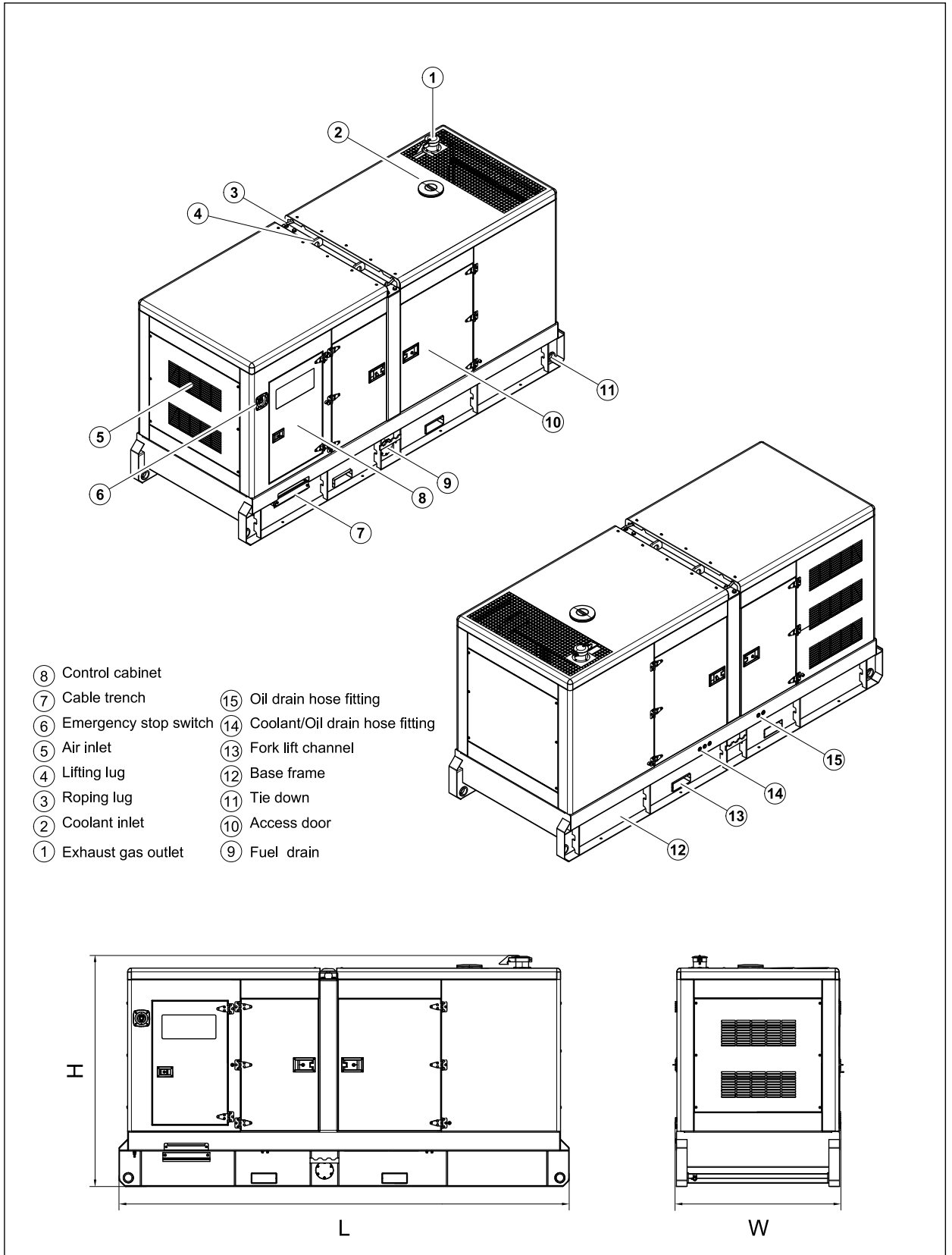

5 Control System

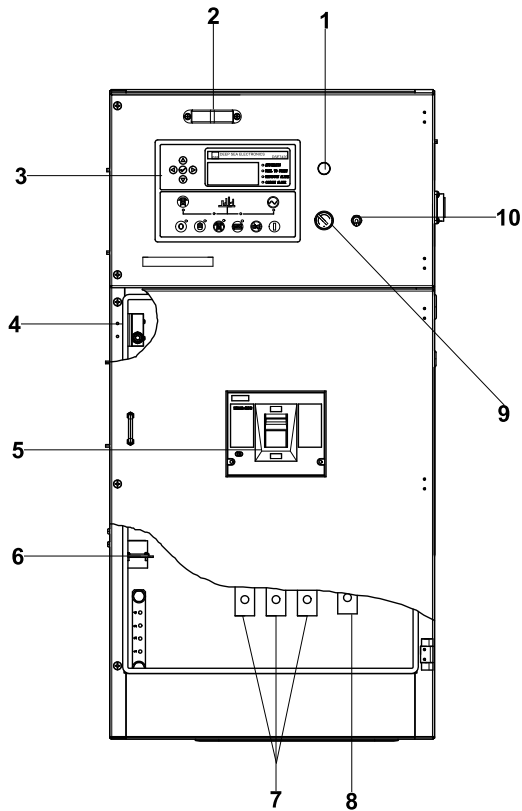

Control & field wiring cabinet

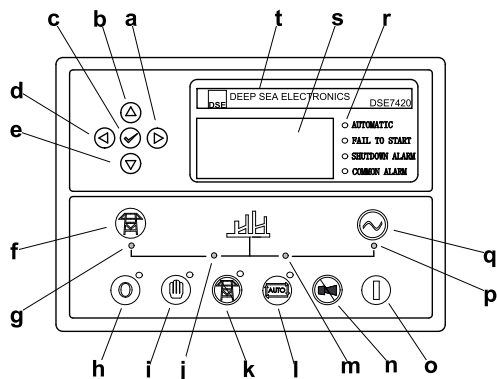

Control module

Ref.	Description
1	Charge indicator
2	Control panel lamp
3	Control module
4	Limit switch
5	Main circuit breaker
6	Mains input/ remote/ AMF communication connector
7	Live wire terminals
8	Neutral wire terminal
9	Key switch
10	Control panel lamp switch

a	Button (next page)
b	Button (increase value / previous item)
c	Button (accept)
d	Button (previous page)
e	Button (decrease value / next item)
f	Button (transfer the load to the mains supply, when in Manual mode only)
g	Mains supply available LED
h	Stop / Reset button
i	Manual button (Manual control mode)
j	Mains supply on load LED
k	Test button (Test mode)
l	Auto button (Auto mode)
m	Genset on load LED
n	Mute/Lamp test button
o	Start button (Manual)
p	Genset available LED
q	Button (transfer the load to the genset, when in Manual mode only)
r	Alarm LED (4 alarm items)
s	LCD display
t	Control module name

100029548
02.2023