

SPECIFICATION

POWERLINK
Power Systems

Power Link the World

MODEL VR15PX **VR SERIES** **(FOR 50Hz DIESEL GENSET)**

Revision: B1 (11/21)

To inquire the latest revision of
document, visit our website at:
www.powerlinkworld.co.uk



VR series VR15PX



50 Hz @ 1500rpm,3-phase/5-wiring

1 Standards & Conditions

Design Standards

The designs and the productions are in conformity with:

- Conformance Européenne (CE)
- ISO8528-5:2005
- GB/T2820.5-2009

Environmental Operating Conditions

- Installation place: Outdoors or indoors (well ventilated).
- Ambient temperature: -25°C to 50°C. The coolant heater is needed when the temperature is below 5°C
- Humidity: Less than 90%.
- Altitude: Below one thousand (1000) meters above sea level.

Factory Inspection

- Inspection items.
- Protection devices working test.
- Starting ability in normal temperature.
- 50% rated power load moment capability.
- Voltage deviation and speed variation: 0%, 25%, 50%, 75%, 100%, 110% Load.

Painting Process

- Painting process specifications and colors are based on the manufacturer's standard.
- The customer could also choose the color which the manufacturer offers.

2 General Features

- PowerLink engine VR4-2.3G1
- Close coupled to PowerLink alternator PL1D
- Microprocessor control module PLC-920
- Main circuit breaker: 32A
- Rotate speed governor: Mechanical governor
- Excitation system: Self excited,SHUNT
- A.V.R model: SX440
- Key switch
- Emergency stop switch
- ATS(automatic transfer switch)receptacle

- Remote run connector
- 1x12V/60AH sealed for life maintenance free battery
- Lockable battery isolator switch
- 50°C radiator
- Steel base frame
- Vibration isolators between the engine/alternator and base frame
- Dry type air filter
- Base fuel tank for 10 hours running
- Drain points for fuel tank
- Operation Manual / Specifications

3 Equipment

General technical data

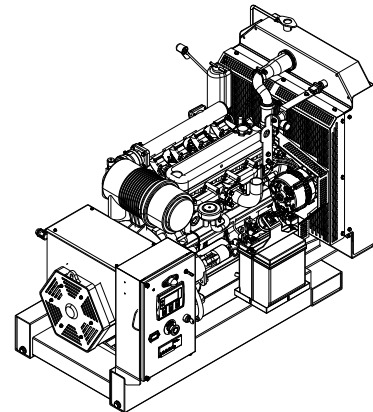

| | |
|---------------------------------|----------------|
| Model..... | VR15PX |
| Structure type | D |
| Tank capacity..... | 32L |
| Dry weight..... | 293kg |
| Sound pressure level @ 7m | N/A |
| Dimensions L×W×H..... | 1340x735x961mm |
| Standby Power | 16kVA/13kW |
| Prime Power..... | 15kVA/12kW |

| | | | | | |
|--------------------------------|-------|-------|-------|-------|------|
| Voltage | 380V | 400V | 415V | 440V | |
| Ampere | 22.7A | 21.6A | 20.8A | 19.6A | |
| Genset Fuel Consumption | | | | | |
| Frequency/Load | 25% | 50% | 75% | 100% | 110% |
| 50Hz (L/h) | 0.9 | 1.7 | 2.5 | 3.3 | 3.6 |

Dck Yf' GrghYa

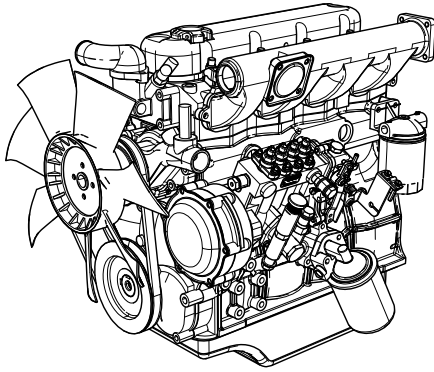

| | |
|--------------------------------|---------------------|
| Engine Manufacturer/Brand..... | PowerLink |
| Engine Model..... | VR4-2.3G1 |
| Dimensions L×W×H..... | 744x546x635mm |
| Dry Weigh (approx.) | 220Kg |
| Number of Cylinders..... | 4 |
| Bore..... | 85mm |
| Stroke | 100mm |
| Displacement..... | 2.3L |
| Compression Ratio..... | 18.5 |
| Type of injection..... | Direct injection |
| Intake System..... | Natural aspirated |
| Intake Resistance..... | ≤5kPa |
| Cooling System | Water cooled |
| Fan | Pusher |
| Battery Voltage..... | 12V |
| Type of Fuel..... | No.2 or ASTM D975 |
| Type of Oil | API CF/SE or CCMCF4 |
| Oil Capacity | 3.5L |
| Type of Coolant | Glycol mixture |
| Coolant Capacity..... | 3.0L |
| Back Pressure | ≤10.1kPa |
| Standby Power | 18kW |
| Prime Power | 16kW |

Alternator

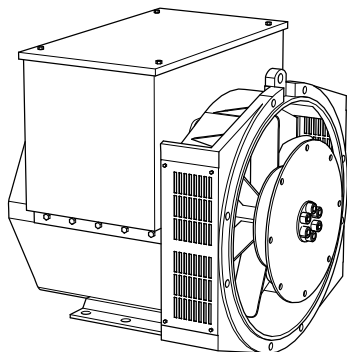

| | |
|---|---------------------|
| Alternator Manufacturer/Brand | PowerLink |
| Alternator Model | PL1D |
| Exciter..... | Brushless |
| Cooling Fan | Cast alloy aluminum |
| Windings..... | 100% copper |
| Insulation Class | H |
| Winding Pitch..... | 2/3 |
| Terminals | 12 |
| Drip Proof | IP23 |
| Altitude..... | ≤1000m |
| Overspeed | 2250rpm |
| Air Flow..... | N/A |
| Voltage Regulation | ±1.0% |
| Total Harmonic TGH / THCat no load < 1.5 % - on load < 5% | |
| Telephone Interference..... | THF<2%;TIF<50 |

PLC-920 Control System

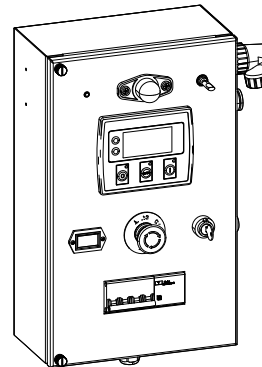

PLC-920 is an advanced control module based on microprocessor designed to control the engine via push buttons on the front panel. The module is used to start and stop the engine and indicate fault conditions, automatically shutting down the engine and giving a true first up fault condition of an engine failure.

Standard Control Function

- Manual Engine Control Module
- Low Oil Pressure
- High Engine Temperature
- Auxiliary Shutdown
- Overspeed Protection
- Protection hold-off timer
- Charge Failure warning

4 Overall Dimensions

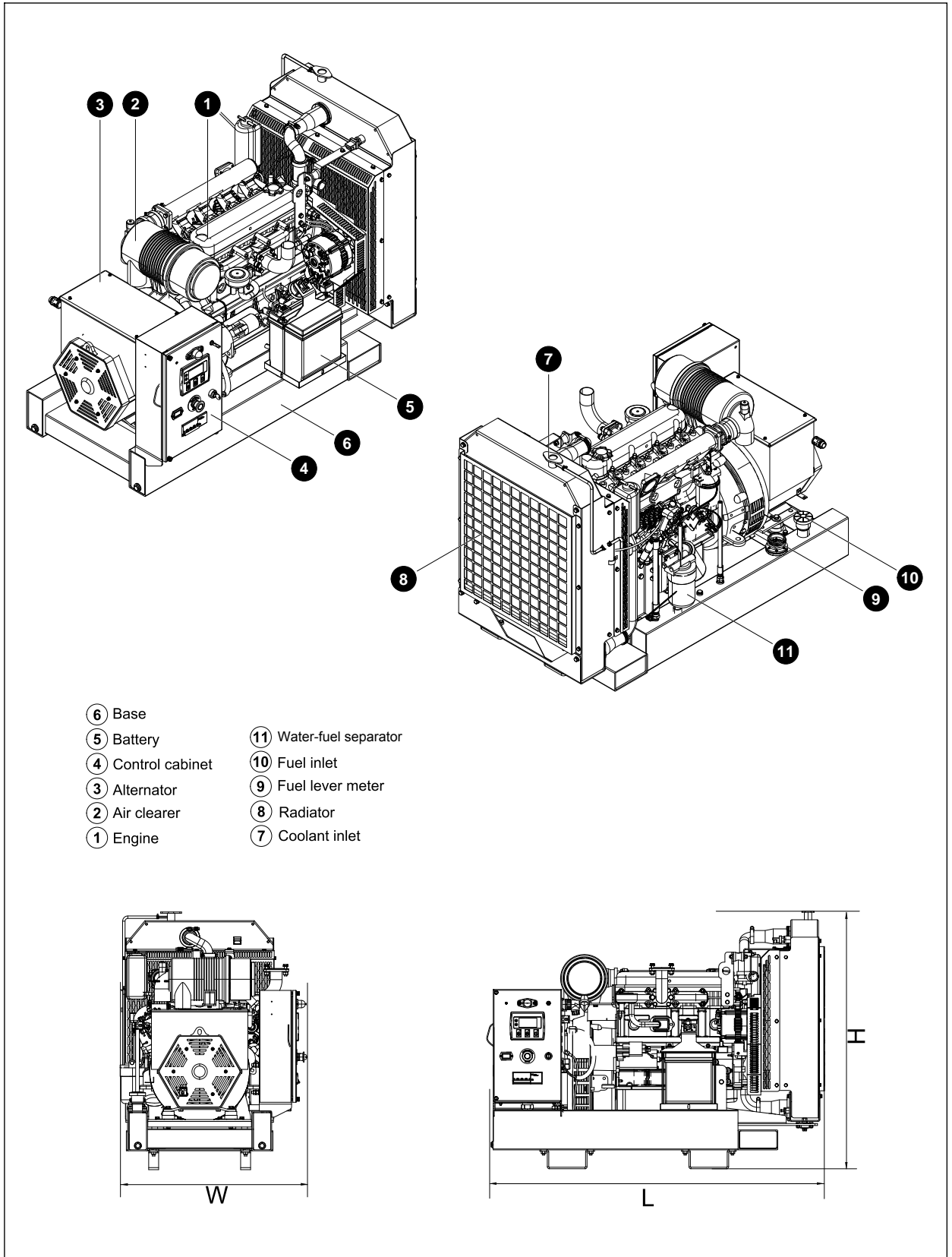

5 Control System

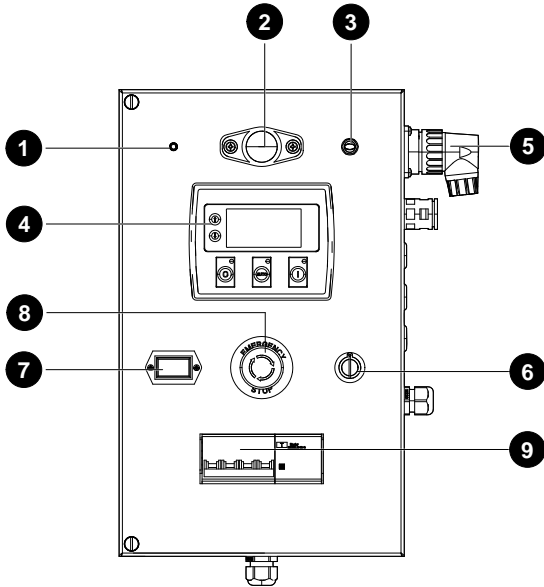

Control&Field wiring cabinet

| Ref. | Description |
|------|-----------------------------|
| 1 | Charge indicator |
| 2 | Control cabinet lamp |
| 3 | Control cabinet lamp switch |
| 4 | Control module |
| 5 | Control cables connector |
| 6 | Key switch |
| 7 | Time counter |
| 8 | Emergency stop switch |
| 9 | Main circuit breaker |

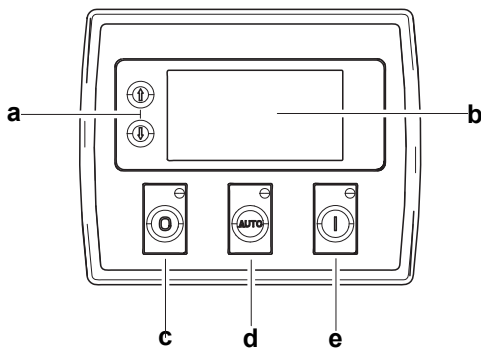

Control module

| Ref. | Description |
|------|---|
| a | Navigation button Accept (Configuration mode only) |
| b | Main status display |
| c | Stop/reset button Next page (Configuration mode only) |
| d | Auto start button Decrease value/next item (Configuration mode only) |
| e | Start button Increase value/next item (Configuration mode only) |

SPECIFICATION

VR SERIES DIESEL GENSET

VR15PX

Revision: B1 (11/21)

To inquire the latest revision of
document, visit our website at:
www.powerlinkworld.co.uk

